

## Description

The DCSM712 is designed for asymmetrical (12V to -7V) protection in multi-point data transmission application. The DCSM712 replace four discrete components by integrating two 12V and two 7V TVS diodes in a single package. The DCSM712 complies with the IEC 61000-4-2 (ESD) standard with  $\pm 30\text{kV}$  air and  $\pm 30\text{kV}$  contact discharge. It is assembled into a lead-free SOT-23 package. It is designed to protect components which are connected to data and transmission lines from voltage surges.

## Features

- ◆ 325W peak pulse power(8/20 $\mu\text{s}$ )
- ◆ Ultra low leakage: nA level
- ◆ Operating voltage: 7V or 12V
- ◆ Low clamping voltage
- ◆ Complies with following standards:
  - IEC 61000-4-2 (ESD) immunity test Air discharge:  $\pm 30\text{kV}$   
Contact discharge:  $\pm 30\text{kV}$
  - IEC61000-4-5 (Lightning) 13A (8/20 $\mu\text{s}$ )
- ◆ RoHS Compliant

## Mechanical Characteristics

- ◆ Package: SOT-23
- ◆ Lead Finish: Matte Tin
- ◆ Case Material: "Green" Molding Compound.
- ◆ Moisture Sensitivity: Level 3 per J-STD-020
- ◆ Terminal Connections: See Diagram Below
- ◆ Marking Information: See Below

## Applications

- ◆ Wireless System
- ◆ Networks
- ◆ Portable Instrumentation
- ◆ RS485 Ports

## Dimensions and Pin Configuration

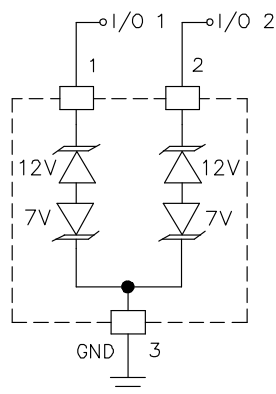

Circuit Schematic

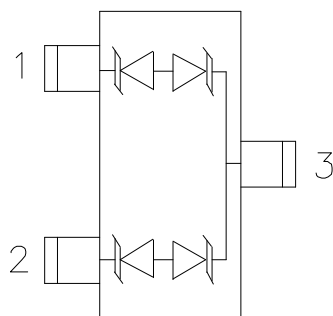

Pin Schematic

## Marking Information

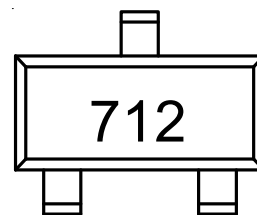

## Ordering Information

Part Number	Marking	Packaging	Reel Size
DCSM712	712	3000/Tape & Reel	7 inch

### Absolute Maximum Ratings ( $T_A=25^{\circ}\text{C}$ unless otherwise specified)

Parameter	Symbol	Value	Unit
Peak Pulse Power(8/20 $\mu\text{s}$ )	Ppk	325	W
Peak Pulse Current(8/20 $\mu\text{s}$ )	I <sub>PP</sub>	13	A
ESD per IEC 61000-4-2 (Air)	V <sub>ESD</sub>	±30	kV
ESD per IEC 61000-4-2 (Contact)		±30	
Operating Temperature Range	T <sub>J</sub>	-55 to +125	°C
Storage Temperature Range	T <sub>stg</sub>	-55 to +150	°C

### Electrical Characteristics ( $T_A=25^{\circ}\text{C}$ unless otherwise specified)

Parameter	Symbol	Pin 1 to 3 and 2 to 3 (12V TVS)			Pin 3 to 1 and 3 to 2 (7V TVS)			Unit	Test Condition
		Min	Typ	Max	Min	Typ	Max		
Reverse Working Voltage	V <sub>RWM</sub>			12			7	V	
Breakdown Voltage	V <sub>BR</sub>	13.3			7.5			V	I <sub>T</sub> = 1mA
Reverse Leakage Current	I <sub>R</sub>			0.5			0.5	μA	V <sub>R</sub> = V <sub>RWM</sub>
Clamping Voltage	V <sub>C</sub>			20			14	V	I <sub>PP</sub> = 5A (8 x 20μs pulse)
Clamping Voltage	V <sub>C</sub>			25			16	V	I <sub>PP</sub> = 13A (8 x 20μs pulse)
Junction Capacitance	C <sub>J</sub>		40			40		pF	V <sub>R</sub> = 0V, f = 1MHz
Junction Capacitance	C <sub>J</sub>		20			30		pF	V <sub>R</sub> = V <sub>RWM</sub> , f = 1MHz

**Typical Performance Characteristics (TA=25°C unless otherwise Specified)**

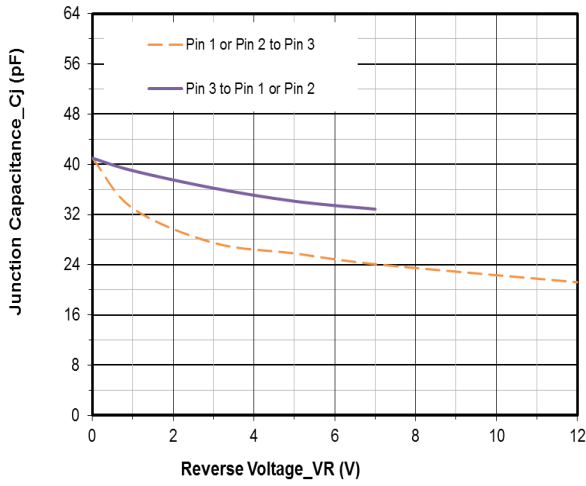

**Junction Capacitance vs. Reverse Voltage**

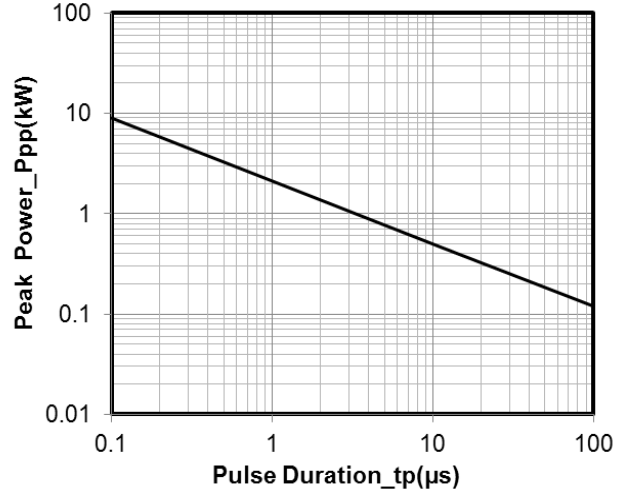

**Peak Pulse Power vs. Pulse Time**

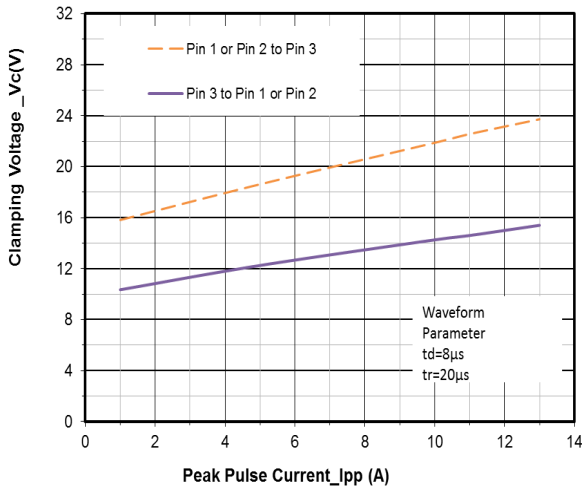

**Clamping Voltage vs. Peak Pulse Current**

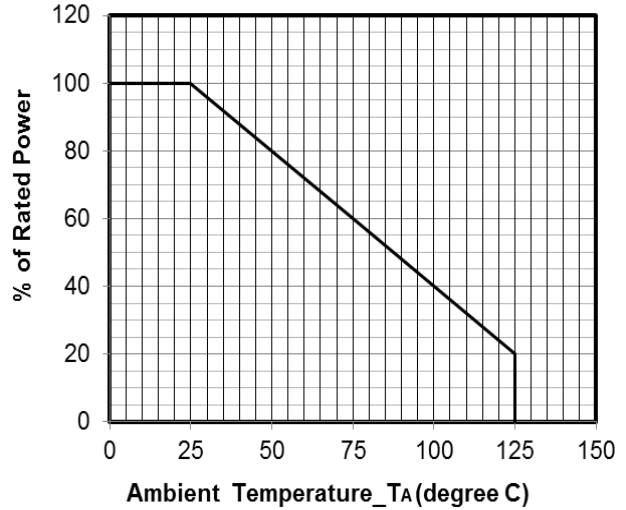

**Power Derating Curve**

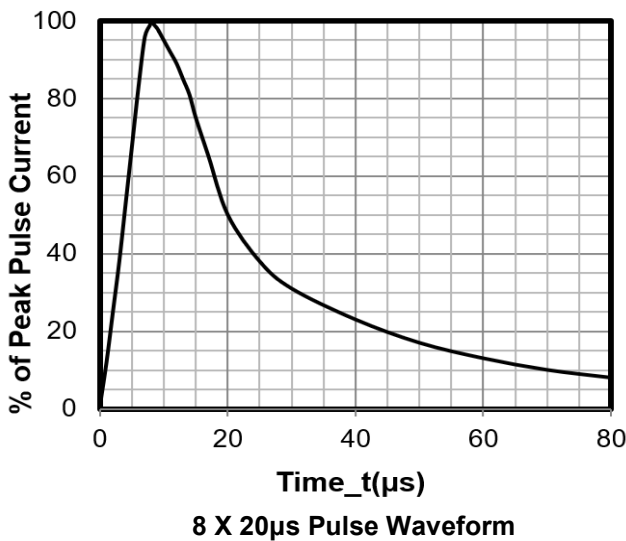

**8 X 20μs Pulse Waveform**

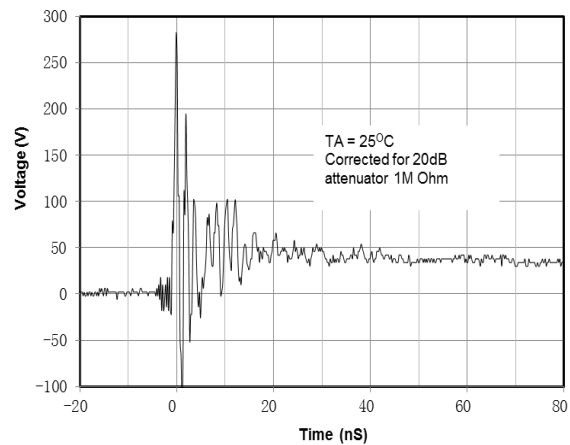

**ESD Clamping Voltage**

**8 kV Contact per IEC61000-4-2**

## DCSM712 on RS-485 Data Lines Application

EIA RS-485 specifies a  $\pm 7V$  ground difference between devices on the bus. This permits the bus voltage to range from +12V (5V + 7V) to -7V (0 - 7V). The DCSM712 is designed to protect two RS-485 data lines in extended common mode applications. The DCSM712 may be used to protect devices from transient voltages resulting from ESD, EFT, and lightning. The device is designed with asymmetrical operating voltages for optimum protection. The TVS diodes at pins 1 and 2 have a working voltage of 12 volts. These pins are connected to the differential data line pairs. The TVS diodes at pin 3 have a working voltage of 7 volts. Pin 3 is connected to ground. The internal TVS diodes of the DCSM712 will protect the transceiver input from positive transient voltage spikes greater than 12V and negative spikes greater than 7V.

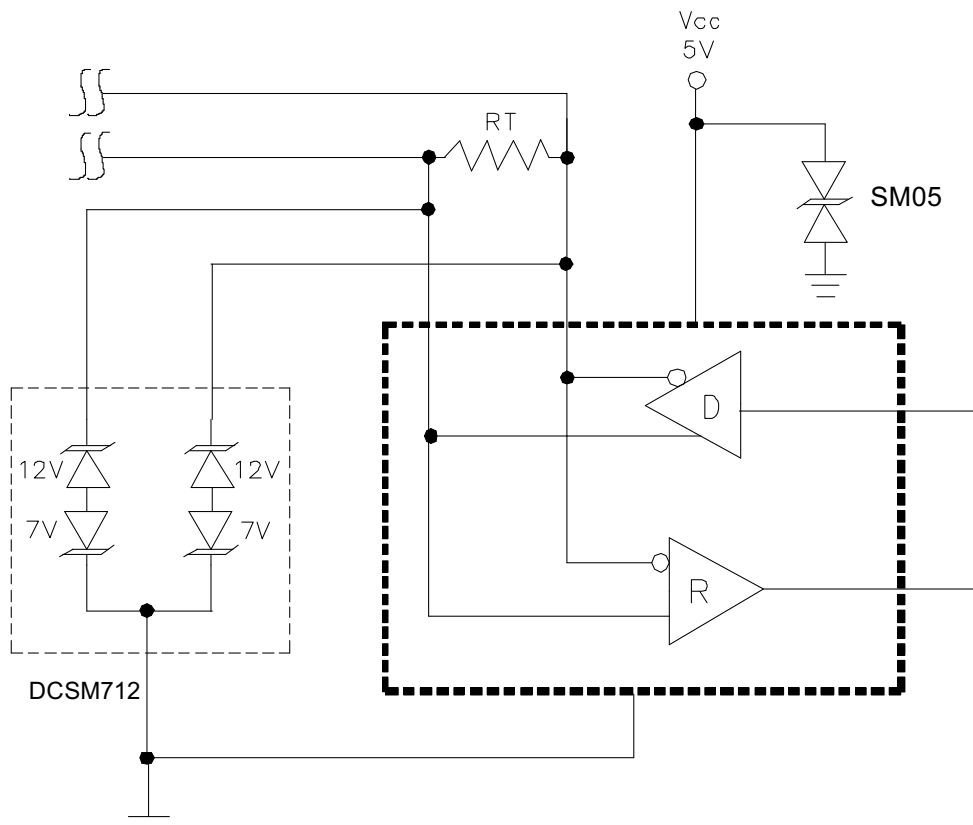

### SOT-23 Package Outline Drawing

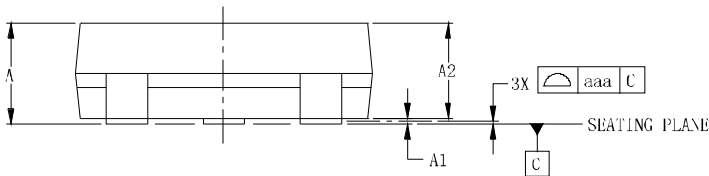
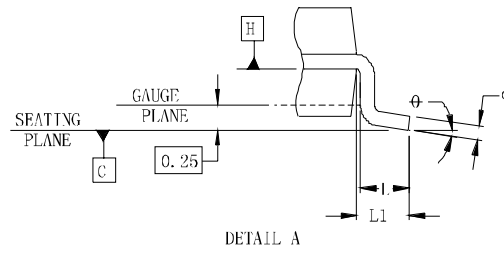
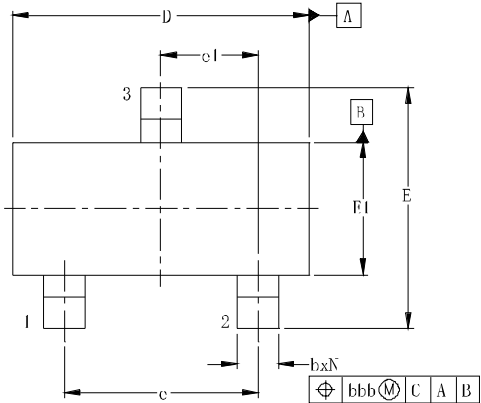

### Suggested Land Pattern

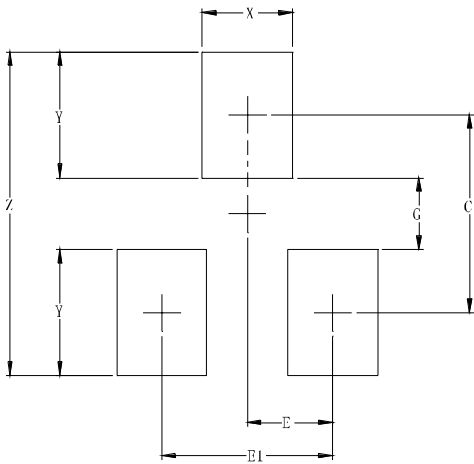

DIMENSIONS						
SYM	INCHES			MILLIMETERS		
	MIN	NOM	MAX	MIN	NOM	MAX
A	0.035	-	0.044	0.89	-	1.12
A1	0.000	-	0.004	0.01	-	0.10
A2	0.035	0.037	0.040	0.88	0.95	1.02
b	0.012	-	0.020	0.30	-	0.51
c	0.003	-	0.007	0.08	-	0.18
D	0.110	0.114	0.120	2.80	2.90	3.04
E	0.082	0.093	0.104	2.10	2.37	2.64
E1	0.047	0.051	0.055	1.20	1.30	1.40
e	0.075			1.90BSC		
e1	0.037			0.95BSC		
L	0.015	0.020	0.024	0.40	0.50	0.60
L1	0.022			0.55		
N	3			3		
ϕ	0°	-	8°	0°	-	8°
aaa	0.004			0.10		
bbb	0.008			0.20		

DIMENSIONS		
SYM	INCHES	MILLIMETERS
C	0.087	2.20
E	0.037	0.95
E1	0.075	1.90
G	0.031	0.80
X	0.039	1.00
Y	0.055	1.40
Z	0.141	3.60

### Contact Information

Changzhou D-first Electronics CO.,Ltd.

www.first-electronic.com

Email: xhf@first-electronic.cn

Phone: +86 (0519) 8817 1671